

PRODUCTPROFILE

Catalogue number: 041A1912OM4

Partnumber: 746254

PreCONNECT® TRUNK MULTIJUMPER
24 channels, 48 fibers, 50/125µmOM4, violett
Connector side A: LC-Compact MM
Connector side B: LC-Compact MM
Cable U-DQ(ZN)BH4x12G50/125µmOM4



Related documents:

DS_FASER OM4BI_OE	Fiber Data Sheet
DS_LC_COMPACT_STECKER_SHORT_C	Steckerdatenblatt
DS_U-DQZNBH4x12G50/125µmOM4	Kabeldatenblatt

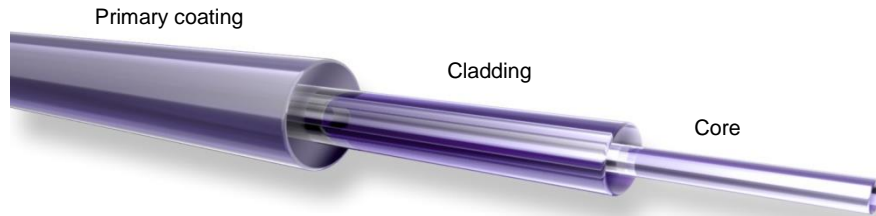

Standards

Graded index fiber 50/125µm according to
 -ISO/IEC 11801 und EN 50173-1 OM4
 -IEC 60793-2-10 type A1a.3
 -ITU G.651.1
 -TIA/EIA 492AAAD

Structure

Silica fiber with two layer acrylate primary coating

Geometrical properties

Core diameter	50 µm +/- 2.5 µm
Cladding diameter	125 µm +/- 1 µm
Core non-concentricity	< 5 %
Cladding non-circularity	< 1 %
Core-Cladding concentricity	< 1.5 µm
Primary coating diameter	242 µm +/- 5 µm
Coating-Cladding concentricity	< 12 µm

Mechanical properties

Break strength SCREEN-Test 1 % strain for 1 s @100 kpsi

Thermal properties

Operating temperature range -60 to +85°C

Dieses Dokument ist urheberrechtlich geschützt • This document is protected by copyright • Rosenberger OSI GmbH & Co. OHG

Transmission characteristics

Attenuation:

@ 850 nm max. 2.3 dB/km
@ 1300 nm max. 0.6 dB/km

Macrobending, induced attenuation:

100 turns, 37.5 mm \leq 0.05 dB @ 850 nm
100 turns, 37.5 mm \leq 0.15 dB @ 1300 nm
2 turns, 15 mm \leq 0.1 dB @ 850 nm
2 turns, 15 mm \leq 0.3 dB @ 1300 nm
2 turns, 7.5 mm \leq 0.2 dB @ 850 nm
2 turns, 7.5 mm \leq 0.5 dB @ 1300 nm

Bandwidth (Overfilled launch):

@ 850 nm min. 3500 MHz x km
@ 1300 nm min. 500 MHz x km

Effective modal Bandwidth-length-product (EMB):

@ 850 nm min. 4700 MHz x km

Numerical aperture: 0.200 +/- 0.015

Effective group index of refraction:

@ 850 nm 1.480
@ 1300 nm 1.479

Backscatter attenuation @ 1ns pulse width:

@ 850 nm -68 dB
@ 1300 nm -76 dB

Maximum possible transmission channels lengths:

Ethernet:

1 GBE 100GBASE-SX: min. 1100 m @ max. 3.56 dB channel attenuation ¹⁾
10 GBE 10GBASE-SR: min. 550 m @ max. 2.60 dB channel attenuation ¹⁾
40 GBE 40GBASE-SR4: min. 170 m @ max. 1.50 dB channel attenuation ¹⁾
100 GBE 100GBASE-SR10: min. 170 m @ max. 1.50 dB channel attenuation ¹⁾

Fibre Channel:

8 GFC (800-SN): min. 245 m @ max. 1.76 dB channel attenuation ¹⁾
16 GFC (1600-SN): min. 165 m @ max. 1.51 dB channel attenuation ¹⁾

¹⁾ Inclusive max. 1.0 dB for connections (connectors and splices)

While the information has been carefully compiled to the best of our knowledge, nothing is intended as representation or warranty on our part and no statement herein shall be construed as recommendation to infringe existing patents. In the effort to improve our products, we reserve the right to make changes judged to be necessary.

Draft	Date	Approved	Date	Rev.	Engineering change number	Name	Date
H. Jungbäck	26-10-15	P. Maier	26-10-15	004	without	H. Jungbäck	26-10-15

LC-COMPACT Shortboot connector

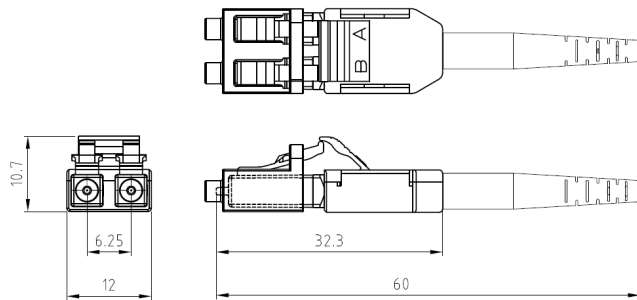

Properties and applications

- LC-Duplex connector with compact and rugged backshell with short central strain relief and boot for round cable (Uniboot)
- A/B polarity can be easily tool-less changed
- The short boot enables the use of the connector in applications with low depth, like ODF Optical Distribution Frames
- Translucence duplex protection cap, fast and secure to handle and permeable for the light of laser pointers (visual fault locators)

Standards

LC-Duplex acc. to IEC/DINEN 61754-20 and EIA/TIA 604-10

Material

- Ferrule: Zirconia ceramic, Ø 1.25 mm
- Body: PEI, flammability UL94-V0
- Boot: TPE, flammability UL94-V0
- Protection cap: POM, flammability UL94-HB

Optical properties

The quality feature of the connector at your product is identified by the part number:

- BASIC: Part numbers like XXXAXXXX
- PURE: Part numbers with "P" at their end, XXXAXXXXP

Details about PURE see Produktinfo_Qualitätsmerkmal-PURE_od

Insertion Loss IL acc. to IEC61300-3-4, Method B, against reference, maximum [dB]:

	Quality feature	BASIC	PURE
- Singlemode SM, 9/125µm		0.30	0.20
- Multimode OM1, 62.5/125µm		0.30	---
- Multimode low IL OM2, OM3, OM4, OM5, 50/125µm		0.15	0.15

Insertion Loss IL „random mated“ acc. to IEC61300-3-34, Method 2, [dB]:

Quality feature	BASIC	mean value	maximum
- Singlemode SM, 9/125µm		0.13	0.50
- Multimode low IL OM2, OM3, OM4, OM5, 50/125µm		0.03	0.27

Insertion Loss IL quality feature PURE "random mated" application limit value, maximum [dB]:

- Singlemode SM, 9/125µm	97%	0.25
- Multimode low IL OM2, OM3, OM4, OM5, 50/125µm	100%	0.40

GHMT PVP certificate
No.: c6997X-XX
No.: c6998X-XX



Dieses Dokument ist urheberrechtlich geschützt • This document is protected by copyright • Rosenberger OSI GmbH & Co. OHG

LC-COMPACT Shortboot connector

Optical properties

Return Loss RL acc. to IEC61300-3-6, Method 1, against reference, minimum [dB]:

	Quality feature	BASIC	PURE
- Singlemode SM, 9/125µm, PC 0°		45	45
- Singlemode SM, 9/125µm, UPC 0°		55	55
- Singlemode SM, 9/125µm, APC 8°		65	70
- Multimode all classes		35	40

Mechanical properties

- Mating cycles min. 1000, IL increase < 0.2 dB
- Strain relief max. 100 N, dependent on cable type

Thermal properties

- Operation temperature range -40°C to +85°C, dependent on cable type
- Storage temperature range -40°C to +85°C

Cable diameters

- Round cable types Ø 2.0 to 3.0 mm

Colors

Connector body / boot:

- Singlemode SM, 9/125µm, PC and UPC 0° blue / blue
- Singlemode SM, 9/125µm, APC 8° green / green
- Multimode OM1, 62.5/125µm beige / white
- Multimode OM2, OM3, OM4, OM5, 50/125µm black / black

Polarity change

1) Remove the connector top cover by inserting a fingernail or a small lever into the crack that separates the two halves.

2) Carefully swap position of the connectors by lifting them up and out of the bottom housing.

3) Reposition the top cover and snap into place.



While the information has been carefully compiled to the best of our knowledge, nothing is intended as representation or warranty on our part and no statement herein shall be construed as recommendation to infringe existing patents. In the effort to improve our products, we reserve the right to make changes judged to be necessary.

Draft	Date	Approved	Date	Rev.	Engineering change number	Name	Date
H. Jungbäck	2018-12-13	A. Burggraf	2018-12-13	009	----	H. Jungbäck	2022-10-07

Fiber Optic Cable
U-DQ(ZN)BH nxm 4000N GHMT PVP certified

030AXXX

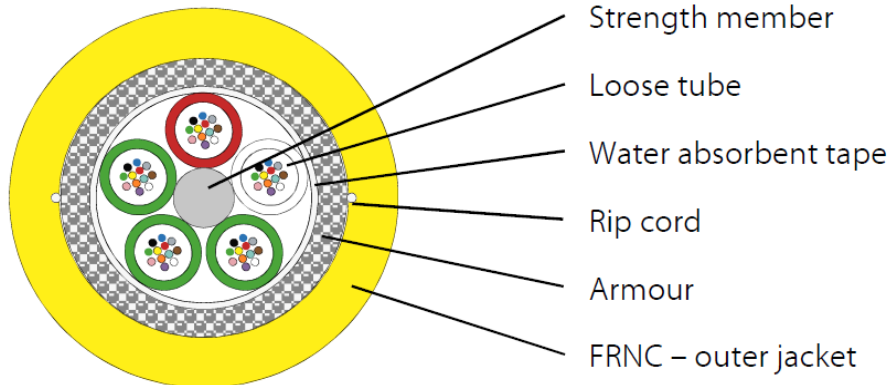

PVP only with singlemode and OM4 fibers

Standards

IEC 60794-2
EN 50575: 2014 + A1: 2016: No. of Declaration of Performance CDERF0000090

Structure

- Loose tube** Jelly filled loose tube, outer diameter 2.3 mm with 2–12 colour-coded optical fibres
Fibre colours: red, green, blue, yellow, white, grey, brown, violet, turquoise, black, orange, pink
Tube colours: counting tube red, counting direction tube white, other tubes yellow (E9/125), green (G50/125), or blue (G62.5/125)
- Stranding** Loose tubes and if necessary fillers stranded around a central strength member (FRP). Strength member can be upcoated.
With water absorbent tape.
- Armour** Multifunctional E-glass yarns, wrapped in two layers (left and right spin), as strain relief elements and non-metallic rodent protection
- Outer jacket** Halogen-free and flame-retardant material (FRNC), with approx. 1.5mm
Standard colours: Singlemode yellow
 Multimode 50 µm: orange or green
 Multimode OM3: aqua (turquoise)
 Multimode OM4: violett
 Multimode OM5: limegreen
 Multimode 62,5 µm: orange
Marking see separate drawing
Two diametrically opposed ripcords under the jacket
Outer diameter see table below

Constr uction	max. no. of fibers	Outer diameter [mm]	Weight [kg/km]	Fire load [MJ/m]	min. bending radius [mm]	
					during installation	installed
1 x m	12	11,5	136	1,90	230	170
2 x m	24	11,5	136	1,90	230	170
3 x m	36	11,5	136	1,90	230	170
4 x m	48	11,5	136	1,90	230	170
5 x m	60	11,5	136	1,90	230	170
6 x m	72	11,5	136	1,90	230	170
8 x m	96	11,9	156	2,10	235	175
10 x m	120	13,2	182	2,80	265	200
12 x m	144	15,7	245	4,60	320	240

Dieses Dokument ist urheberrechtlich geschützt • This document is protected by copyright • Rosenberger OSI GmbH & Co. OHG

Fiber Optic Cable

U-DQ(ZN)BH nxm 4000N GHMT PVP certified

030AXXXX

Mechanical characteristics

- Max. tensile force acc. IEC 60794-1-2 E1 **4000 N**
- Max. crush resistance acc. IEC 60794-1-2 E3 **3000 N/dm, 10 min. (long term)**
- Impact resistance acc. IEC 60794-1-2 E4 **5 impacts, 3.0 Nm, R = 12.5 mm**
- Cable bend acc. IEC 60794-1-2 E11A **1 cycle, R = 10 x outer diameter, n = 5 (windings)**
- Longitudinally watertight acc. IEC 60794-1-2 F5A **l = 3 m, t = 24 h**

Thermal characteristics

- Transport and storage **- 40 °C to + 70 °C**
- Installation **- 5 °C to + 50 °C**
- In use acc. IEC 60794-1-2 F1 **- 40 °C to + 60 °C**

Chemical Characteristics

UV-resistance of outer-jacket

Fire performance

- Cable is flame-retardant acc. to IEC 60332-1-2 and IEC 60332-3-22 Cat. A
- Smoke density acc. to IEC 61034
- Halogen-free acc. to IEC 60754-1
- Acidity of the combustion gases acc. to IEC 60754-2
- Fire Class according EN 13501-6 E_{ca}

Transmission characteristics

See fiber data sheets

Application

- Dry, longitudinally and transversely waterproof fibre optic cable with non-metallic rodent protection and for higher tensile force
- Good installation through ripcords to open the jacket
- For fixed installation indoor and outdoor, in cable ducts, tubes and also suitable for interconnections
- Mechanical installation is only permitted when using force measuring devices with recording function
- Not suitable for underground laying (direct buried)

Packaging

Disposable drums

While the information has been carefully compiled to the best of our knowledge, nothing is intended as representation or warranty on our part and no statement herein shall be construed as recommendation to infringe existing patents. In the effort to improve our products, we reserve the right to make changes judged to be necessary.

Draft	Date	Approved	Date	Rev.	Engineering change number	Name	Date
S. Wiener	2020-02-14	H. Jungbäck	2020-02-14	001			