

PRODUCTPROFILE

Catalogue number: 087A6612G657A1

Partnumber: 743560

Fiber optic duplex patchcord
Connector side A: LC-Compact SM-APC
Connector side B: LC-Compact SM-APC
9/125µm, double jacket 2.8/5.0mm, yellow
Polarity: crossed A to B
Cable I-V(ZN)H(ZN)H2E9/125µmG657A



Related documents:

DS_FASER G657A1_OE	Fiber Data Sheet
DS_I-VZNHZNH28_5_2X900_L_OE	Cable Data Sheet
DS_LC_COMPACT_STECKER_SHORT_C	Steckerdatenblatt

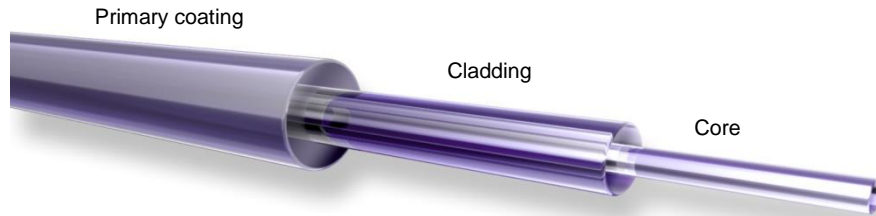

Standards

Stepped index fiber 9/125µm according to
 -ISO/IEC 11801 und EN 50173-1 OS2
 -IEC 60793-2-50 type B1.3
 -ITU G.657.A1 und G.652.D

Structure

Silica fiber with two layer acrylate primary coating

Geometrical properties

Modefield diameter @1310 nm	9.2 µm +/- 0.4 µm
Modefield diameter @1550 nm	10.4 µm +/- 0.5 µm
Cladding diameter	125 µm +/- 0.07 µm
Cladding non-circularity	≤ 0.7 %
Core-Cladding concentricity	≤ 0.5 µm
Primary coating diameter	242 µm +/- 5 µm
Coating-Cladding concentricity	< 12 µm

Mechanical properties

Break strength SCREEN-Test 1 % strain for 1 s @100 kpsi

Thermal properties

Operating temperature range -60 to +85°C

Dieses Dokument ist urheberrechtlich geschützt • This document is protected by copyright • Rosenberger OSI GmbH & Co. OHG

Transmission characteristics

Attenuation:

Cabled fiber tight buffered: @ 1310 nm max. 0.38 dB/km
@ 1550 nm max. 0.28 dB/km

Cabled fiber loose tube: @ 1310 nm max. 0.36 dB/km
@ 1550 nm max. 0.22 dB/km

Uncabled fiber: @ 1310 nm max. 0.32 dB/km
@ 1383 nm max. 0.32 dB/km
@ 1490 nm max. 0.21 dB/km
@ 1550 nm max. 0.18 dB/km
@ 1625 nm max. 0.20 dB/km

Macrobending, induced attenuation, uncabled fiber:

Radius 10 mm, 1 turn, @ 1550 nm ≤ 0.50 dB
Radius 10 mm, 1 turn, @ 1625 nm ≤ 1.50 dB
Radius 15 mm, 10 turns, @ 1550 nm . 0.05 dB
Radius 15 mm, 10 turns, @ 1625 nm ≤ 0.30 dB
Radius 25 mm, 100 turns, @ 1310, 1550 und 1625 nm ≤ 0.01 dB

Dispersion:

@ 1285 - 1330 nm ≤ 3.0 ps/(nm*km)
@ 1550 nm ≤ 18.0 ps/(nm*km)
@ 1625 nm ≤ 22.0 ps/(nm*km)

Polarization Mode Dispersion (PMD):

PMD Link Design Value ≤ 0.04 ps/√km
Maximum individual fiber PMD ≤ 0.1 ps/√km

Cut-off-Wavelength: ≤ 1260 nm

Effective group index of refraction:

@ 1310 nm 1.4676
@ 1550 nm 1.4682

Backscatter attenuation @ 1ns pulse width:

@ 1310 nm -77 dB
@ 1550 nm -82 dB
@ 1625 nm -83 dB

While the information has been carefully compiled to the best of our knowledge, nothing is intended as representation or warranty on our part and no statement herein shall be construed as recommendation to infringe existing patents. In the effort to improve our products, we reserve the right to make changes judged to be necessary.

Draft	Date	Approved	Date	Rev.	Engineering change number	Name	Date
H. Jungbäck	12-04-15	P. Maier	12-04-15	001	without	H. Jungbäck	12-04-15

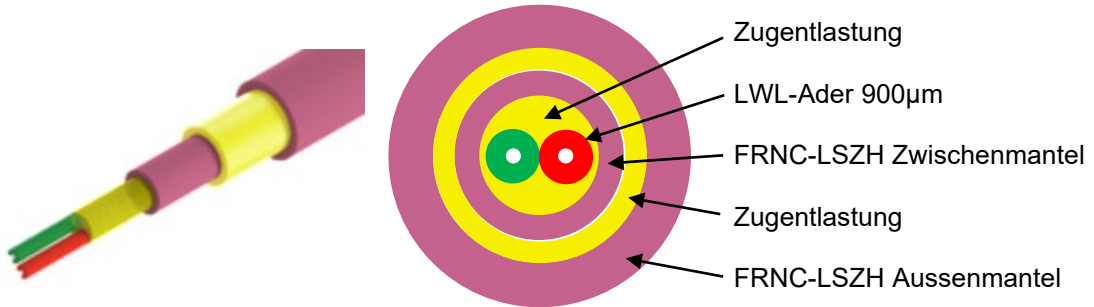

Standards

IEC 60794-2

Structure

Cable:

- Double jacket cable
- 2 buffered optical fibers 900µm within the inner cable jacket filled with Aramid strain relief elements
- Aramid strain relief elements between inner and outer cable jacket
- Buffered fiber color code: One buffered fiber red, the other buffered fiber at singlemode yellow, at 50µm multimode green

Inner and outer jacket:

- FRNC-LSZH flame-retardant and halogen-free material
- Standard jacket colors:
 - Singlemode: yellow
 - Multimode OM2: orange or green
 - Multimode OM3: aqua (turquoise)
 - Multimode OM4: violet
 - Multimode OM5: fibrous green
- Wall thickness see geometrical properties
- Inkjet marking black acc. to separate drawing

Geometrical properties

Number of fibers	Diameter [mm]		Jacket wall thickness [mm]		Weight [kg/km]	Fire load [MJ/m]
	Inner	Outer	Inner	Outer		
2	2.8	5.0	0.4	0.6	20	0.48

Dieses Dokument ist urheberrechtlich geschützt • This document is protected by copyright • Rosenberger OSI GmbH & Co. OHG

Fiber Optic Cable
I-V(ZN)H(ZN)H 2.8/5.0mm 2x900

032AXXXX

Mechanical properties

- Min. bending radius fixed (static) 10 x outer diameter
- Min. bending radius during installation (dynamic) 15 x outer diameter
- Max. tensile force short term = 600 N
- Max. crush resistance long term = 300 N/dm
- Kink resistance: Equivalent loop diameter = 24.5 mm

Thermal properties

- | | |
|-----------------------|------------------|
| Transport and storage | - 25°C to + 70°C |
| Installation | - 5°C to + 50°C |
| In use | - 10°C to + 70°C |

Chemical properties

No resistance to oil, petrol, acid, leach and water

Fire performance

- Flame-retardant acc. to IEC 60332-1-2 and IEC 60332-3-22 Cat.A
- Smoke density acc. to IEC 61034
- Halogen-free acc. to IEC 60754-1
- Acidity of the combustion gases acc. to IEC 60754-2

Transmission characteristics

See fiber data sheets

Applications

Indoor cable particularly appropriate for long LC-Compact and MU-Compact Patchcords

Deliveryform

On one-way drums

While the information has been carefully compiled to the best of our knowledge, nothing is intended as representation or warranty on our part and no statement herein shall be construed as recommendation to infringe existing patents. In the effort to improve our products, we reserve the right to make changes judged to be necessary.

Draft	Date	Approved	Date	Rev.	Engineering change number	Name	Date
H. Jungbäck	16-02-02	P. Maier	16-02-02	003	without	H. Jungbäck	2021-08-25

LC-COMPACT Shortboot connector

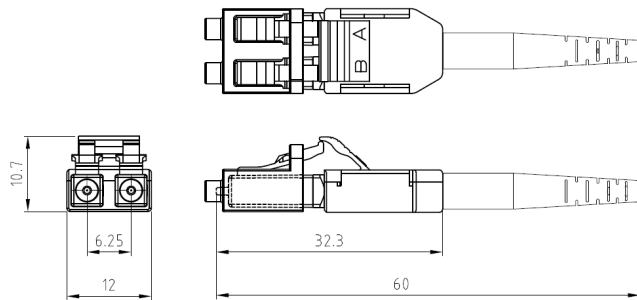

Properties and applications

- LC-Duplex connector with compact and rugged backshell with short central strain relief and boot for round cable (Uniboot)
- A/B polarity can be easily tool-less changed
- The short boot enables the use of the connector in applications with low depth, like ODF Optical Distribution Frames
- Translucence duplex protection cap, fast and secure to handle and permeable for the light of laser pointers (visual fault locators)

Standards

LC-Duplex acc. to IEC/DINEN 61754-20 and EIA/TIA 604-10

Material

- Ferrule: Zirconia ceramic, Ø 1.25 mm
- Body: PEI, flammability UL94-V0
- Boot: TPE, flammability UL94-V0
- Protection cap: POM, flammability UL94-HB

Optical properties

The quality feature of the connector at your product is identified by the part number:

- BASIC: Part numbers like XXXAXXXX
- PURE: Part numbers with "P" at their end, XXXAXXXXP

Details about PURE see Produktinfo_Qualitätsmerkmal-PURE_od

Insertion Loss IL acc. to IEC61300-3-4, Method B, against reference, maximum [dB]:

	Quality feature	BASIC	PURE
- Singlemode SM, 9/125µm		0.30	0.20
- Multimode OM1, 62.5/125µm		0.30	---
- Multimode low IL OM2, OM3, OM4, OM5, 50/125µm		0.15	0.15

Insertion Loss IL „random mated“ acc. to IEC61300-3-34, Method 2, [dB]:

Quality feature	BASIC	mean value	maximum
- Singlemode SM, 9/125µm		0.13	0.50
- Multimode low IL OM2, OM3, OM4, OM5, 50/125µm		0.03	0.27

Insertion Loss IL quality feature PURE "random mated" application limit value, maximum [dB]:

- Singlemode SM, 9/125µm	97%	0.25
- Multimode low IL OM2, OM3, OM4, OM5, 50/125µm	100%	0.40

GHMT PVP certificate
No.: c6997X-XX
No.: c6998X-XX



Dieses Dokument ist urheberrechtlich geschützt • This document is protected by copyright • Rosenberger OSI GmbH & Co. OHG

LC-COMPACT Shortboot connector

Optical properties

Return Loss RL acc. to IEC61300-3-6, Method 1, against reference, minimum [dB]:

	Quality feature	BASIC	PURE
- Singlemode SM, 9/125µm, PC 0°		45	45
- Singlemode SM, 9/125µm, UPC 0°		55	55
- Singlemode SM, 9/125µm, APC 8°		65	70
- Multimode all classes		35	40

Mechanical properties

- Mating cycles min. 1000, IL increase < 0.2 dB
- Strain relief max. 100 N, dependent on cable type

Thermal properties

- Operation temperature range -40°C to +85°C, dependent on cable type
- Storage temperature range -40°C to +85°C

Cable diameters

- Round cable types Ø 2.0 to 3.0 mm

Colors

Connector body / boot:

- Singlemode SM, 9/125µm, PC and UPC 0° blue / blue
- Singlemode SM, 9/125µm, APC 8° green / green
- Multimode OM1, 62.5/125µm beige / white
- Multimode OM2, OM3, OM4, OM5, 50/125µm black / black

Polarity change

1) Remove the connector top cover by inserting a fingernail or a small lever into the crack that separates the two halves.

2) Carefully swap position of the connectors by lifting them up and out of the bottom housing.

3) Reposition the top cover and snap into place.



While the information has been carefully compiled to the best of our knowledge, nothing is intended as representation or warranty on our part and no statement herein shall be construed as recommendation to infringe existing patents. In the effort to improve our products, we reserve the right to make changes judged to be necessary.

Draft	Date	Approved	Date	Rev.	Engineering change number	Name	Date
H. Jungbäck	2018-12-13	A. Burggraf	2018-12-13	009	----	H. Jungbäck	2022-10-07